

# Summit II

## Soft-Fail Modular SSPA/SSPB Systems

### Product Description

The **Summit II** High-Power, Modular, Soft-Fail Redundant SSPA systems from Advantech Wireless Technologies are high power, wide bandwidth, all outdoor ruggedized systems that allow operation with multiple carriers and outstanding linearity. The new modular **Summit II** system is comprised of 4, 8 or 16 amplifiers that are phase combined into a single amplifier that can generate extremely high levels of RF output power – up to 10,000 watts or more. **Summit II** is available in C, X, Ku and S-band architectures.

### Features

- Highest Availability – no single point of failure.
- 30% smaller and lighter than Summit
- Modularity allows systems to be upgraded in the field
- Well suited for antenna platform mounting
- Flying-Master Control Redundancy
- Lightning-fast monitor & control with diagnostics down to the transistor-level
- Half of the time required for system integration and test
- Interactive touch-screen controller
- Controlled Area Network (CAN) BUS M&C Protocol
- Ideally suited for large embedded systems



**SUMMIT II**  
**8 Module System**



## Summit II Soft-Fail Modular SSPA/SSPB Systems

### System Overview

**Summit II** is the next generation of our popular Summit high-power SSPA system. Each amplifier (or module) is arranged in a four, eight or sixteen module assembly that is factory integrated, tested and delivered as a complete system.

The SSPAs in the Summit systems are phase combined to reach the maximum RF output power from N-1 amplifiers, with the output of one amplifier held in reserve for redundancy. In the case of a module failure, the Summit operating system will increase the gain of the remaining amplifiers to bring the total system output power back to the pre-failure level. Switchless, soft-fail redundancy ensures that the system's RF output remains unchanged despite a module failure, unlike switched systems that experience a total interruption of output for the length of time that it takes for the switch to change positions.

### Summit versus Summit II

**Summit** systems have been produced by Advantech Wireless Technologies for over 7 years. First generation Summit systems are still available for GaAs applications that will be deployed in wide carrier-spacing scenarios. Though the features between Summit and Summit II are similar, **Summit II** incorporates the latest in RF and control technologies.

The Summit II systems are comprised of modules that are housed in our Taurus SSPA package. As a result, Summit II is approximately 30% smaller and lighter – the perfect solution for antenna-platform mounting. Taurus provides optimized thermal management and high-efficiency waveguide combining that includes isolation from the transistor boards. Advantech's latest CANBus operating system provides fast inter-component communications as well as the ability to perform device-level diagnostics.

System components include power modules, waveguide, combiners, loads, phase adjusters, M&C distribution, AC power distribution – all housed in a welded frame. An optional redundant BUC system is available to accommodate L-band inputs. The frame can be modified to facilitate special installations such as full-motion antennas.

### Highest Availability & Lowest Mean Time to Repair (MTTR):

Soft-fail redundancy, passive power-combining and modular architecture allow Summit II to deliver the highest availability and least amount of downtime for repair. Summit II operates via a 'Floating Master' feature such that any module in the system can operate as the master controller. This virtually eliminates single points of failure, resulting in hundreds of thousands of hours of availability.

#### NORTH AMERICA

**USA**  
info.usa@advantechwireless.com

**CANADA**  
Info.canada@advantechwireless.com

#### EUROPE

**UNITED KINGDOM**  
info.uk@advantechwireless.com

#### SOUTH AMERICA

info.latam@advantechwireless.com

**BRAZIL**  
info.brazil@advantechwireless.com

#### ASIA

info.asia@advantechwireless.com

**INDIA**  
info.india@advantechwireless.com

## Summit II Soft-Fail Modular SSPA/SSPB Systems

### C-Band SUMMIT II Power Output

4 Module System				
SSPA Module Power Level	Maximum Output Power 4 modules P <sub>sat</sub>	Maximum Output Power 4 modules P <sub>Linear</sub>	Redundant Output Power, 3 modules P <sub>sat</sub>	Redundant Output Power, 3 modules P <sub>Linear</sub>
<b>C-Band</b>				
800W	2500W (64.0dBm)	1300W (61.0dBm)	1400W (61.5dBm)	700W (58.5dBm)
1000W	3200W (65.0dBm)	1600W (62.0dBm)	1800W (62.5dBm)	900W (59.5dBm)

8 Module System				
SSPA Module Power Level	Maximum Output Power 8 modules P <sub>sat</sub>	Maximum Output Power 8 modules P <sub>Linear</sub>	Redundant Output Power, 7 modules P <sub>sat</sub>	Redundant Output Power, 7 modules P <sub>Linear</sub>
<b>C-Band</b>				
800W	4500W (66.5dBm)	2250W (63.5dBm)	3400W (65.3dBm)	1700W (62.3dBm)
1000W	5600W (67.5dBm)	2800W (64.5dBm)	4300W (66.3dBm)	2160W (63.3dBm)

### X-Band SUMMIT II Power Output

4 Module System				
SSPA Module Power Level	Maximum Output Power 4 modules P <sub>sat</sub>	Maximum Output Power 4 modules P <sub>Linear</sub>	Redundant Output Power, 3 modules P <sub>sat</sub>	Redundant Output Power, 3 modules P <sub>Linear</sub>
<b>X-Band</b>				
800W	2500W (64.0dBm)	1300W (61.0dBm)	1400W (61.5dBm)	700W (58.5dBm)
1000W	3200W (65.0dBm)	1600W (62.0dBm)	1800W (62.5dBm)	900W (59.5dBm)

8 Module System				
SSPA Module Power Level	Maximum Output Power 8 modules P <sub>sat</sub>	Maximum Output Power 8 modules P <sub>Linear</sub>	Redundant Output Power, 7 modules P <sub>sat</sub>	Redundant Output Power, 7 modules P <sub>Linear</sub>
<b>X-Band</b>				
800W	4500W (66.5dBm)	2250W (63.5dBm)	3400W (65.3dBm)	1700W (62.3dBm)
1000W	5600W (67.5dBm)	2800W (64.5dBm)	4300W (66.3dBm)	2160W (63.3dBm)

#### NORTH AMERICA

**USA**  
info.usa@advantechwireless.com

**CANADA**  
Info.canada@advantechwireless.com

#### EUROPE

**UNITED KINGDOM**  
info.uk@advantechwireless.com

#### SOUTH AMERICA

info.latam@advantechwireless.com

**BRAZIL**  
info.brazil@advantechwireless.com

#### ASIA

info.asia@advantechwireless.com

**INDIA**  
info.india@advantechwireless.com

## Summit II Soft-Fail Modular SSPA/SSPB Systems

### Ku-Band SUMMIT II Power Output

4 Module System				
SSPA Module Power Level	Maximum Output Power 4 modules Psat	Maximum Output Power 4 modules P Linear	Redundant Output Power, 3 modules Psat	Redundant Output Power, 3 modules P Linear
<b>Ku-Band (14.0-14.5, 13.75-14.5)</b>				
300W	1000W (60.0dBm)	500W (57.0dBm)	570W (57.5dBm)	280W (54.5dBm)
400W	1300W (61.0dBm)	650W (58.0dBm)	700W (58.5dBm)	360W (55.5dBm)
500W	1600W (62.0dBm)	800W (59.0dBm)	900W (59.5dBm)	450W (56.5dBm)

8 Module System				
SSPA Module Power Level	Maximum Output Power 8 modules Psat	Maximum Output Power 8 modules P Linear	Redundant Output Power, 7 modules Psat	Redundant Output Power, 7 modules P Linear
<b>Ku-Band (14.0-14.5, 13.75-14.5)</b>				
300W	1700W (62.3dBm)	850W (59.3dBm)	1350W (61.3dBm)	675W (58.3dBm)
400W	2250W (63.5dBm)	1125W (60.5dBm)	1700W (62.3dBm)	850W (59.3dBm)
500W	2800W (64.5dBm)	1400W (61.5dBm)	2150W (63.3dBm)	1080W (60.3dBm)

### SUMMIT II - 8 Module System

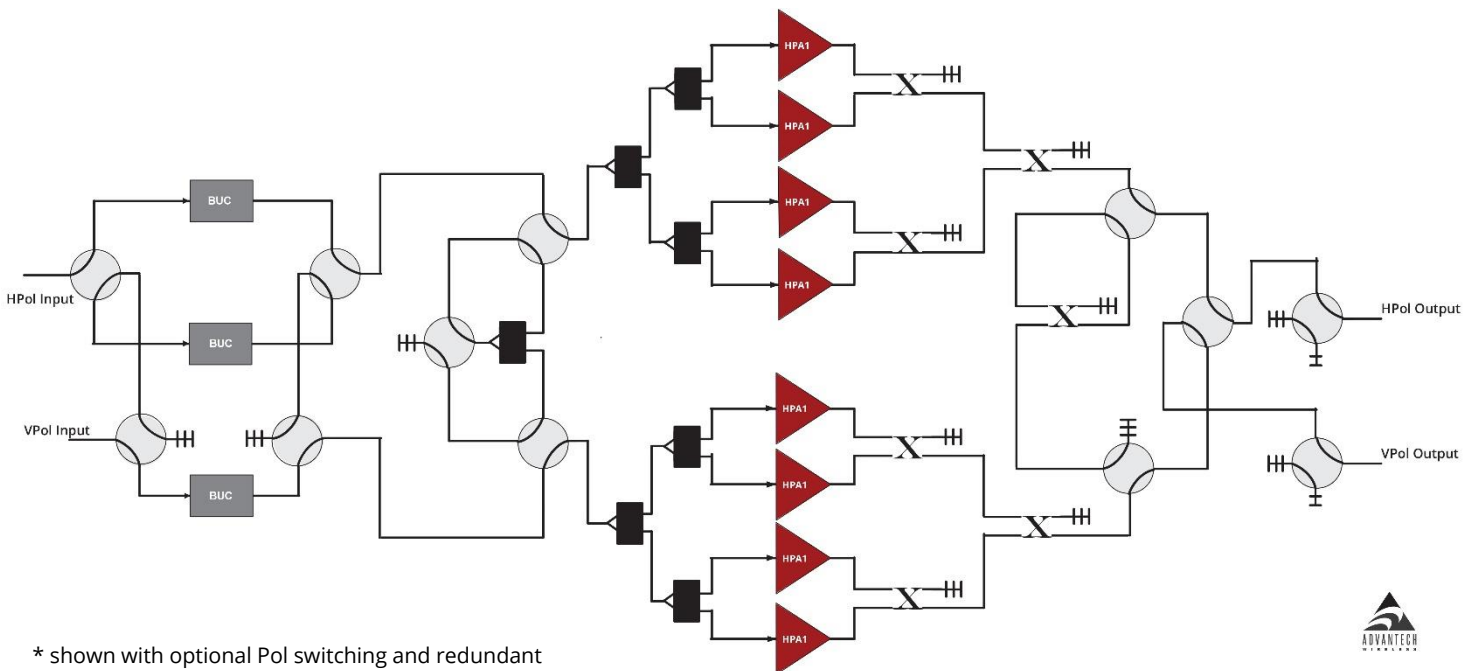

\* shown with optional Pol switching and redundant L-Band BUC input

## Summit II Soft-Fail Modular SSPA/SSPB Systems

### Product Outline



### 8 Module System

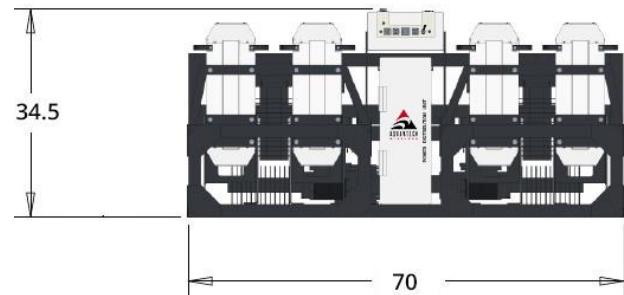
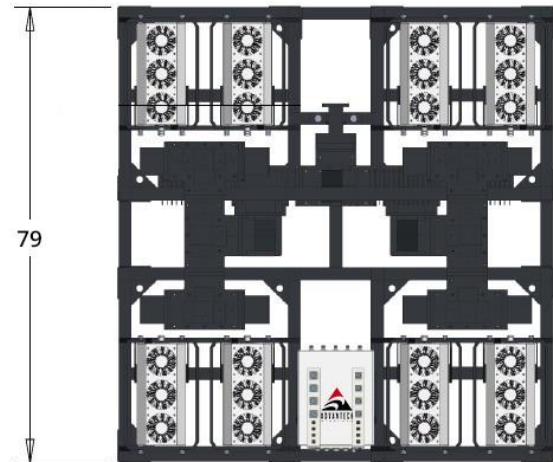

#### NORTH AMERICA

**USA**  
info.usa@advantechwireless.com

**CANADA**  
Info.canada@advantechwireless.com

#### EUROPE

**UNITED KINGDOM**  
info.uk@advantechwireless.com

#### SOUTH AMERICA

info.latam@advantechwireless.com

**BRAZIL**  
info.brazil@advantechwireless.com

#### ASIA

info.asia@advantechwireless.com

**INDIA**  
info.india@advantechwireless.com



## Summit II Soft-Fail Modular SSPA/SSPB Systems

Technical Specifications			
Ku-Band			
Electrical Characteristics	300W	400W	500W
RF Output at P Sat	55 dBm	56 dBm	57 dBm
RF Output at P Lin	52 dBm	53 dBm	54 dBm
Output Frequency Range	Lower Ku: 12.75 – 13.25 GHz	Standard Ku: 14.00 – 14.50 GHz	Extended Ku: 13.75 – 14.50 GHz
Input Frequency Range	Lower Ku: 950 – 1450 MHz	Standard Ku: 950 – 1450 MHz	Extended Ku: 950 – 1700 MHz
Local Oscillator Frequency	Lower Ku: 11.80 GHz	Standard Ku: 13.05 GHz	Extended Ku: 12.80 GHz
Gain Stability Over Temp.	Low Ku Band: ± 1.5 dB nominal; ± 2.25 dB max Standard Band: ± 1.5 dB nominal; ± 2.0 dB max Extended Band: ± 1.5 dB nominal; ± 2.25 dB max		
Gain Variation at fixed temp	Low Ku Band: ± 0.75 dB over max over 40 MHz; ± 2.25 dB over full band Standard Band: ± 0.5 dB over max over 40 MHz; ± 2.0 dB over full band Extended Band: ± 0.75 dB over max over 40 MHz; ± 2.25 dB over full band		
Linear Gain	70 dB min.		
User Adjustable Gain	20 dB nominal in 0.5 dB steps		
C-Band			
Electrical Characteristics	800W	1000W	
RF Output at P Sat	59 dBm	60 dBm	
RF Output at P Lin	56 dBm	57 dBm	
Output Frequency Range	Lower C: 5.725 – 6.425 GHz	Standard C: 5.85 – 6.425 GHz	Extended C: 5.85 – 6.725 GHz Insat C: 6.725 – 7.025 GHz
Input Frequency Range	Lower C: 975 – 1675 MHz	Standard C: 950 – 1525 MHz	Extended C: 950 – 1825 MHz Insat C: 1275 – 1575 MHz
Local Oscillator Frequency	Lower C: 4.75 GHz	Standard C: 4.9 GHz	Extended C: 4.9 GHz Insat C: 5.45 GHz
Gain Stability Over Temperature	± 1.5 dB nominal		
Gain Variation at fixed temperature	± 0.5 dB over max over 36 MHz; ± 2.0 dB over full band		
Linear Gain	70 dB min.		
User Adjustable Gain	20 dB in 0.5 dB steps		
X-Band			
Electrical Characteristics	800W	1000W	
RF Output at P Sat	59 dBm	60 dBm	
RF Output at P Lin	56 dBm	57 dBm	
Output Frequency Range	7.9 – 8.4 GHz		
Input Frequency Range	950 – 1450 MHz		
Local Oscillator Frequency	6.95 GHz		
Gain Stability Over Temperature	± 1.5 dB nominal		
Gain Variation at fixed temperature	± 0.5 dB over max over 40 MHz; ± 2.0 dB over full band		
Linear Gain	70 dB min.		
User Adjustable Gain	20 dB in 0.5 dB steps		

### NORTH AMERICA

**USA**  
info.usa@advantechwireless.com

**CANADA**  
Info.canada@advantechwireless.com

### EUROPE

**UNITED KINGDOM**  
info.uk@advantechwireless.com

### SOUTH AMERICA

info.latam@advantechwireless.com

**BRAZIL**  
info.brazil@advantechwireless.com

### ASIA

info.asia@advantechwireless.com

**INDIA**  
info.india@advantechwireless.com



## Summit II Soft-Fail Modular SSPA/SSPB Systems

Technical Specifications					
Ku, C-Band					
Spectral Re-growth	-30dBc @PLinear				
Third order IMD (2 equal tones 5MHz apart)	-25 dBc, with 2 equal carriers at 3dB total power back off from rated power (P Sat -3dB)				
10MHz Reference	0dBm ± 5.0 dB - External via IF / (Internal 10MHz reference optional)				
	<b>@ 100 Hz</b>	<b>@ 1 KHz</b>	<b>@ 10 KHz</b>	<b>@ 100 KHz</b>	<b>@ 1 MHz</b>
Ref Phase Noise Requirement		-140 dBc/Hz max	-150 dBc/Hz max	-155 dBc/Hz max	
Local Oscillator Phase Noise	-63 dBc/Hz max	-73 dBc/Hz max	-83 dBc/Hz max	-93 dBc/Hz max	-103 dBc/Hz max
Output Spurious	-55dBc max @PLinear				
Harmonics	-50dBc max @PLinear				
VSWR	Input (1:50:1) Output (1.30:1)				
Power consumption					
	Ku-Band	300W	400W	500W	
Power consumption (at rated power) AC version		2400W	2500W	3200W	
	C-Band	800W	1000W		
Power consumption (at rated power) AC version		3500W	3750W		
	X-Band	800W	1000W		
Power consumption (at rated power) AC version		3750W	4000W		
Power requirement	220 VAC				
Interface					
Output Interface	Ku-Band: Waveguide, WR75G (Grooved) C-Band: Waveguide, CPR 137G (Grooved) X-Band: Waveguide, CPR 112G (Grooved)				
Input Interface	N-Type Female, 50 Ohms				
Connectors	AC Connector: MS3102R16-10P	M&C: MS3112E14-19P	Redundancy: MS3112E14-15P (Optional)		
Mechanical					
Dimensions (L x W x H)	16.0 x 22.3 x 7.7 / 40.6 x 56.5 x 19.5				
Weight	93lb / 42kg				
Environmental					
	Temperature Range (ambient)	Humidity	Altitude		
	-40°C to + 55°C (operating) -40°C to + 75°C (storage)	0 to 100% (condensing)	10,000 ft ASL		

Ref.: PB-SUMMIT-II-C-X-KU-001-20321

### NORTH AMERICA

**USA**  
info.usa@advantechwireless.com

**CANADA**  
Info.canada@advantechwireless.com

### EUROPE

**UNITED KINGDOM**  
info.uk@advantechwireless.com

### SOUTH AMERICA

info.latam@advantechwireless.com

**BRAZIL**  
info.brazil@advantechwireless.com

### ASIA

info.asia@advantechwireless.com

**INDIA**  
info.india@advantechwireless.com